

Provision of Engineering & Project Management Services

Presented by :



Headquarter :
Prince Center Building Floor 6 Suite 602-605
Jl. Jenderal Sudirman Kav. 3-4,
Jakarta Pusat, Indonesia
Phone: +6221-573 3966 Fax: +6221-573 8808
Mobile +62 852 1068 5004
Website : www.isb-eng.com
email: info@isb-eng.com

Table of Contents

1. [Company Overview](#)
2. Expertise and Specialization
 - [Structural Engineering](#)
 - [Marine Engineering](#)
 - [Subsea Pipeline Engineering](#)
 - [Mechanical Engineering](#)
 - [Process Engineering](#)
 - [Piping Engineering](#)
 - [Electrical Engineering](#)
 - [Instrumentation Engineering](#)
 - [Project Management Consultancy](#)
3. [Track Records](#)
4. [Contact](#)

Company Overview

PT. Indonesian Service Bureau (ISB), was established in 2003 to provide Engineering & Project Management Services to the Oil/Gas Industry. Over the years, ISB, becomes the established local firm with wide range capabilities that focuses and pride itself on developing quick, practical solution by bringing the combined experience and technical expertise.

ISB possess a full range of Multi-discipline Engineers as well as Project Management Experts Capable to execute major Offshore/Onshore Oil-Gas Projects, including but not limited to the following:

- 1. Front End Engineering Design/FEED Studies, Capital Cost Estimates & Multi Discipline Detail Engineering Design for :**
 1. Fixed Platforms
 2. Floating Production Storage Offloading/FPSO
 3. Storage Tank Farms & Oil Terminals
 4. Floating Storage & Regasification Unit/FSRU
 5. Gas Treatment Facilities & Process Plants
 6. Wellhead Utility Systems & Loading Facilities
- 2. Integrity Assessment** for Existing Oil Gas Production Facilities & Revamping Engineering
- 3. Project Management Consultancy & Construction Management**

Company Overview

Since 2003, ISB has completed major Offshore/Onshore Engineering & Project Management Oil Gas Projects in several countries such as Indonesia, Malaysia, India, Singapore, Qatar, Bangladesh, including but not limited to the following :



Offshore Infrastructure

- Fixed Platforms
 - Platform Facilities/Living Quarters
 - Jackets and Topsides Pre-service Design
 - Jackets and Topsides In-service Design
 - Platforms Integrity Assessment Studies
- Subsea Pipelines
 - Survey & Route Selection
 - Feasibility & Cost Studies
- Floating Production Facilities
 - Spar and Buoy
 - Single Point Mooring
 - Floating Production Storage Offloading/FPSO & FSO Conversions
 - Revamp & Re-certification
 - Fluid Handling
- Fabrication Yard Upgrading



Onshore Infrastructure

- Onshore Process Pipelines
 - Survey & Route Selection
 - Feasibility & Cost Studies
 - Cost/Operation Analysis
- Wellhead Utility Systems
- Oil Terminals
 - Storage Tank Farms
 - Storage/Loading Facilities
 - Gas Treatment Facilities
 - Chemical Process Plant Systems

Expertise & Specialization

Structural Engineering



➤ **Fixed Offshore - In and Pre-service Analysis & Construction Support :**

In-place Static and Dynamic, Spectral Fatigue, Response Spectra and Time History Seismic, Wave and Wind Response, Boat Impact, Vibrated Equipment Support, Transportation Fatigue, [Stabilized Lifting](#), Upending, On-bottom Stability, Sensitivity Loadout, Barge Strength Check, [Steel and Concrete Pile Driveability and Monitoring](#), Skidway and Bulkhead Quayside Design

➤ **Fixed Offshore Assessment :**

Pushover Analysis, Ductility Analysis, [ELE / ALE Seismic with reduced soil strength](#), Non-linear Blast Analysis, Dropped Object Analysis

➤ **Other Capabilities:**

[Cable Structure](#), [Finite Element Analysis](#), Soil T-Z, P-Y, Q-Z Development, Response Spectra Development, Stressed Skin Design for LQ

➤ **Codes Familiarity:**

API RP 2A 22nd Edition, AISC 360-10, ISO 19902-2007, EN10024, ASCE7-10
NORSOK

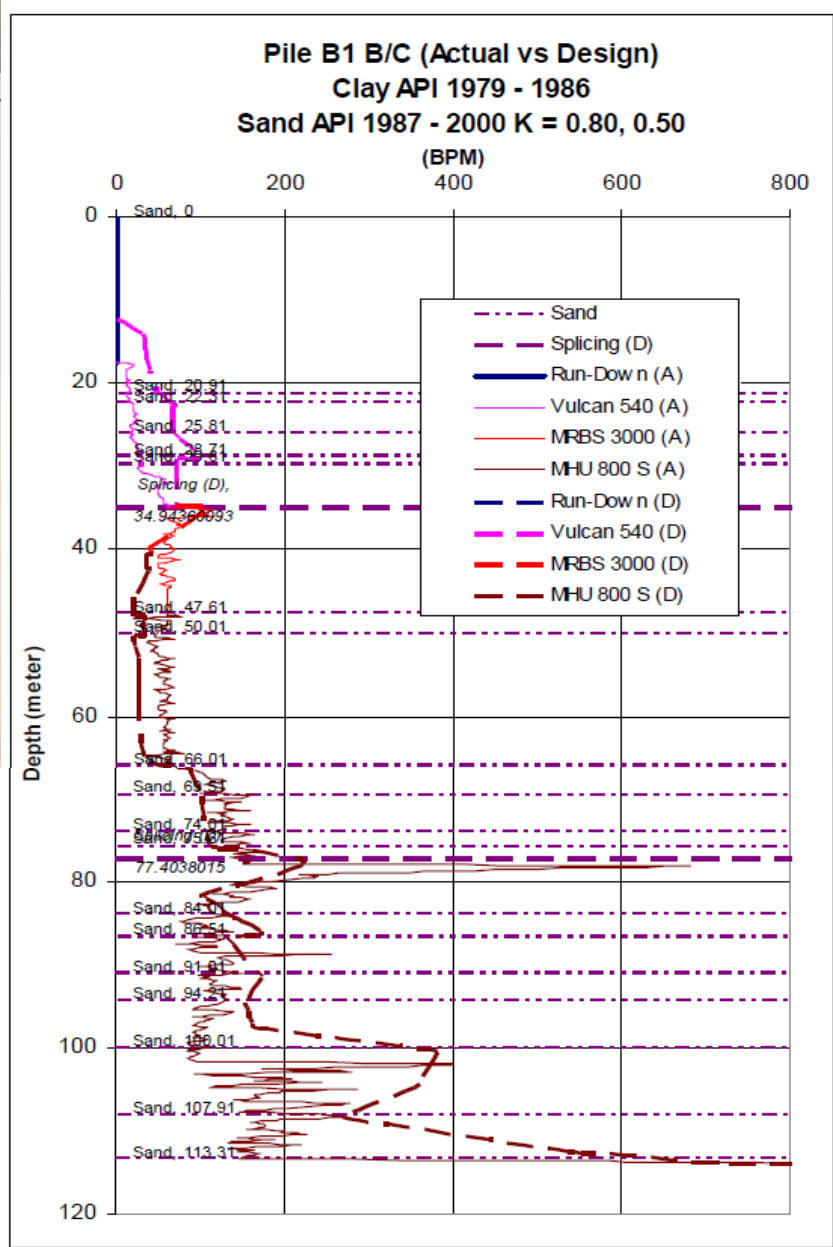

Predicted Blow Count vs Actual's

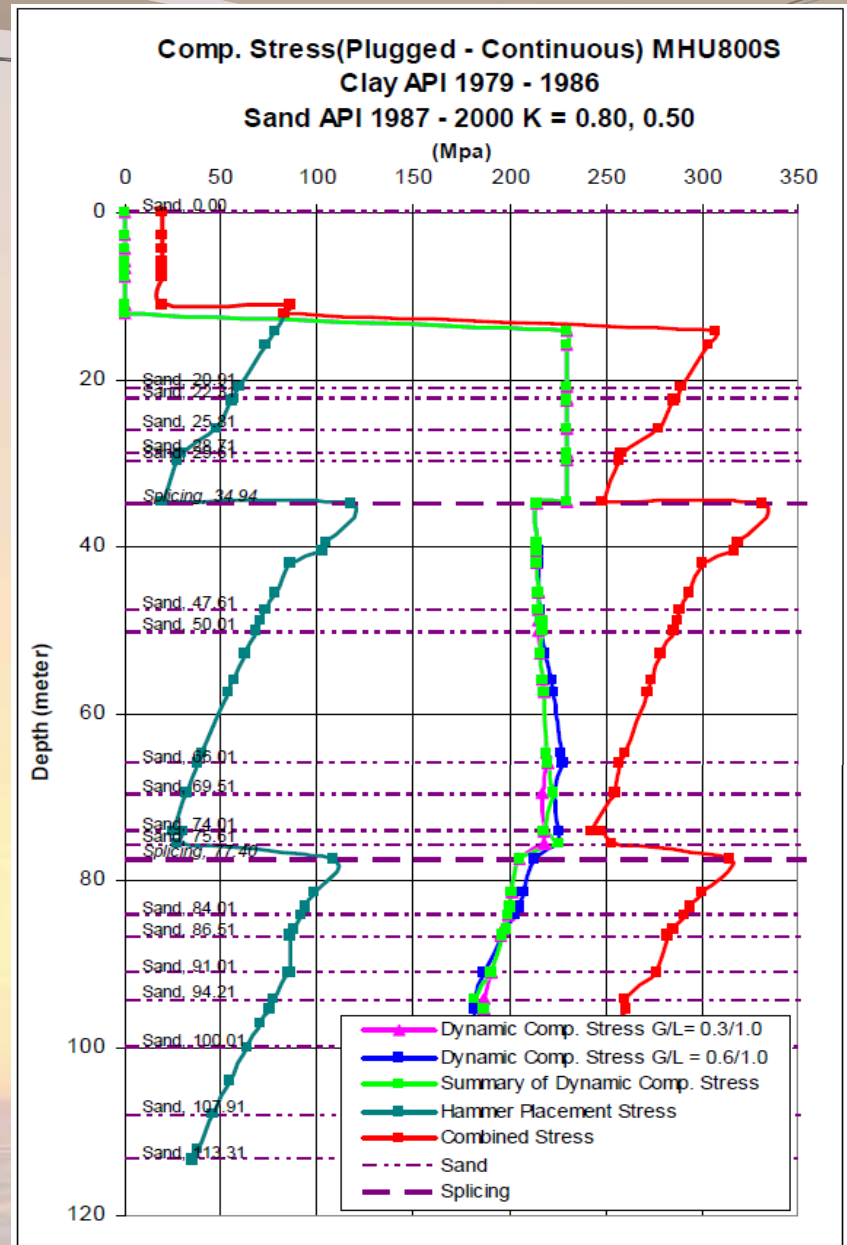

Predicted Combined Stress

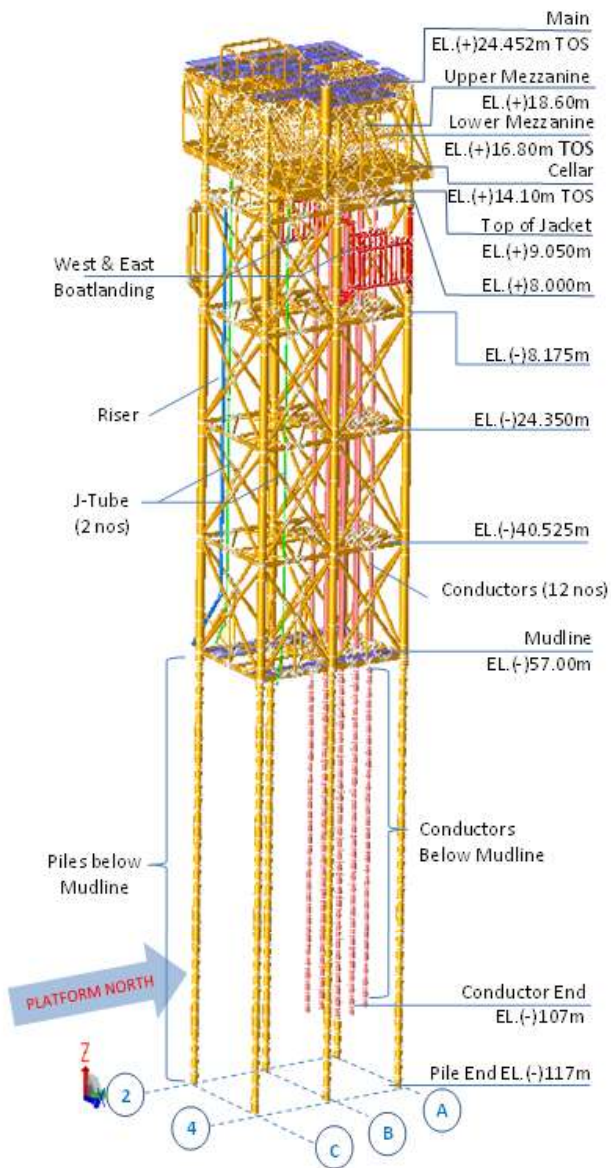

Seismic Model with Pile & Conductor

Pile Convergence Check - Bending Diagram +Y Global

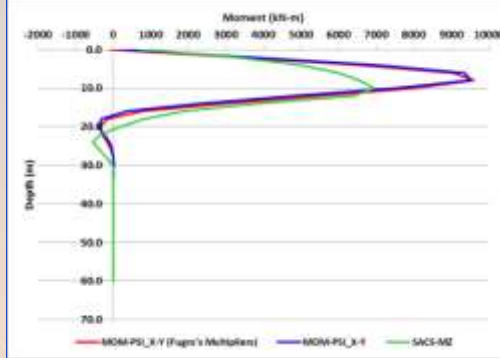

Pile Convergence Check - Bending Diagram +X Global

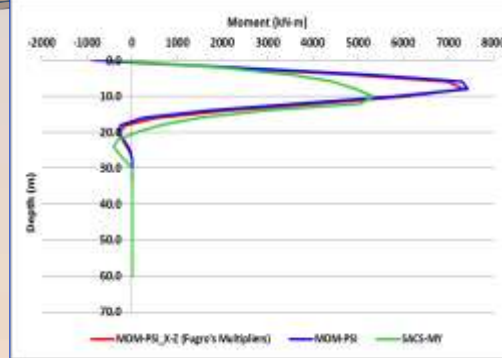

Pile Convergence Check - Shear Diagram +X Global

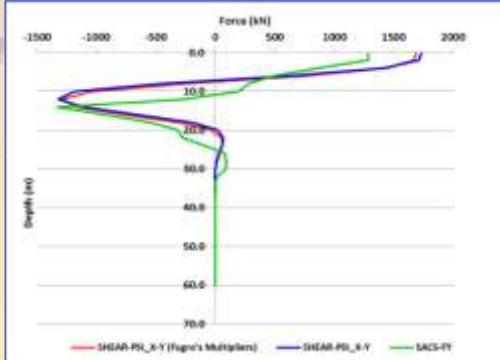

Pile Convergence Check - Shear Diagram +Y Global

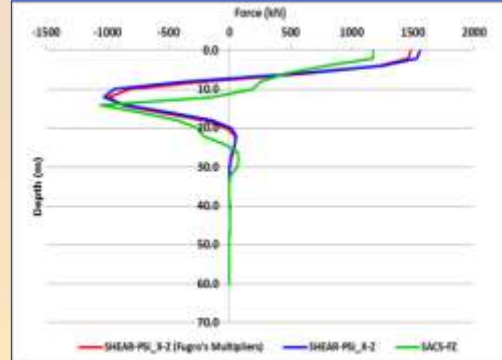

Pile Convergence Check - Lateral Displacement +X

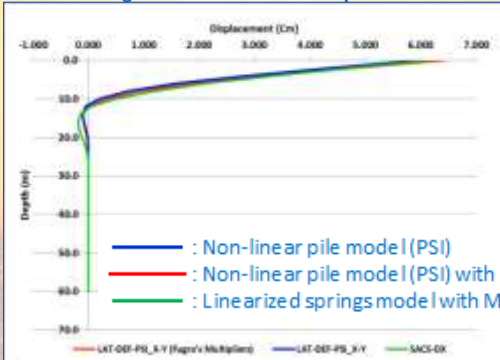

Pile Convergence Check - Lateral Displacement +Y

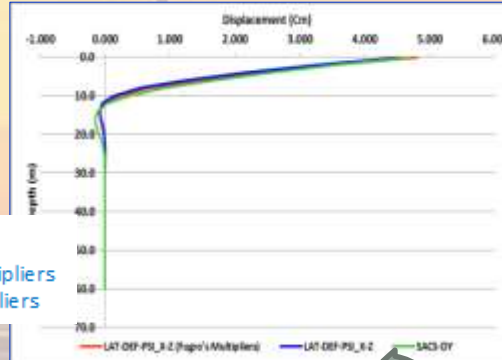

- : Non-linear pile mode I (PSI)
- : Non-linear pile mode I (PSI) with Multipliers
- : Linearized springs mode I with Multipliers

Pile Convergence Check

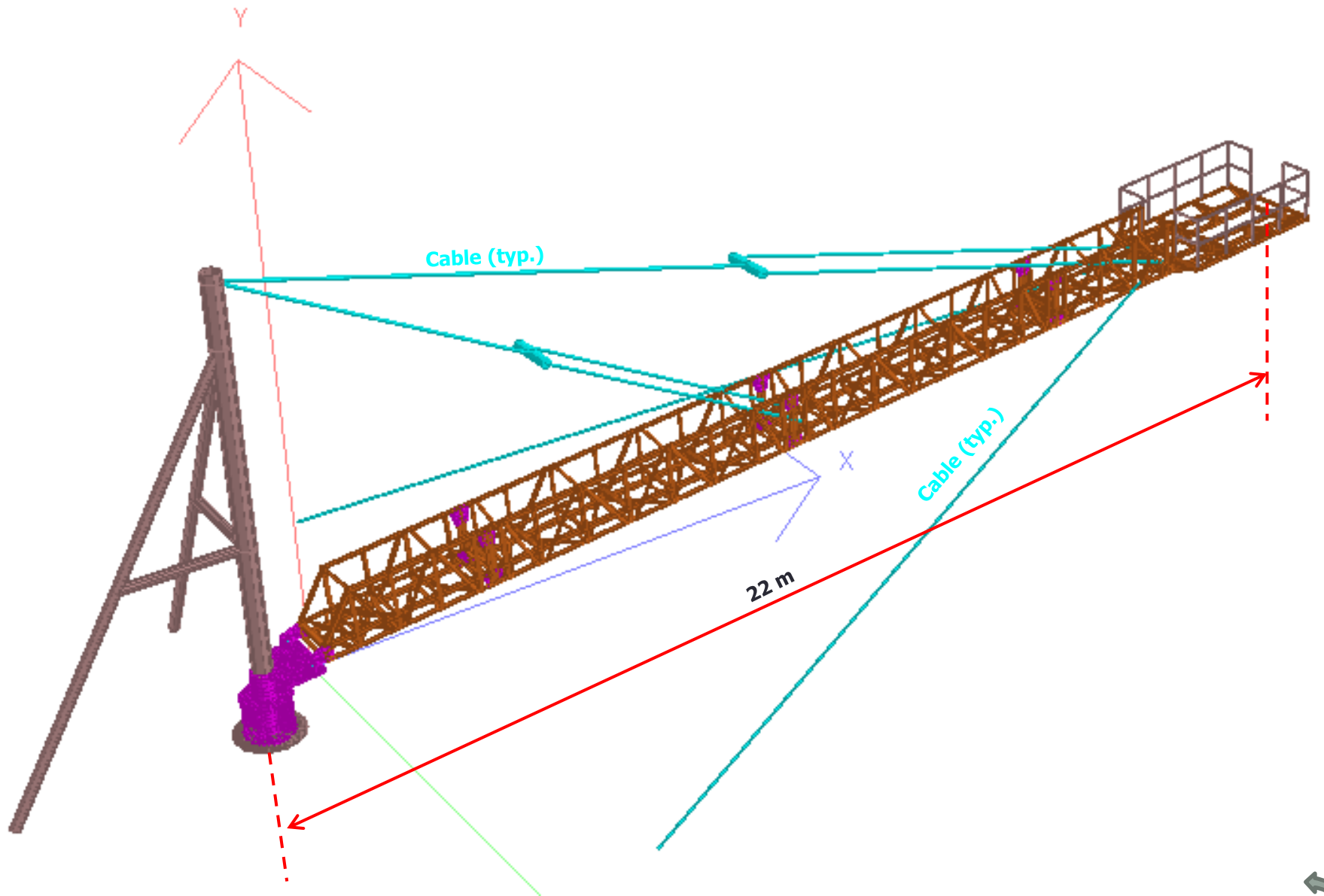

Expertise & Specialization

Marine Engineering



- Mooring analysis (quasi-static, quasi dynamic, dynamic)
- Offshore Loading - Offloading Systems
- In-situ and through-installation analysis
- Riser analysis (rigid, flexible, catenary)
- Application of Classification Society Rules

Expertise & Specialization

Floating Systems

Design of Vessel Conversions, Refurbishments, Jumbonisation, Enhancements covering FPSO, FSO, SPM and Spar Buoys.

- Production facilities Upgrade
- Naval Architectural Design
- Structural modifications
- Process design modifications & enhancements
- Intact & damage stability checks
- Application of Classification Society Rules
- Vessel & Floater dynamic simulations
- Mooring analysis



FPSO SEAGOOD 101 FOR SANTOS (INDONESIA)

Expertise & Specialization

Subsea Pipeline

- Develop route selection criteria
- Supervise survey field and data processing work
- Mechanical Design
- Pipeline hydraulics and sizing
- Upheaval buckling analysis and assessment
- Fatigue assessment
- Riser design (platform risers, J tubes, steel catenary risers, top tensioned hybrid risers)
- Shore approach studies
- Pipeline installation engineering
- Cost analysis
- Stinger design

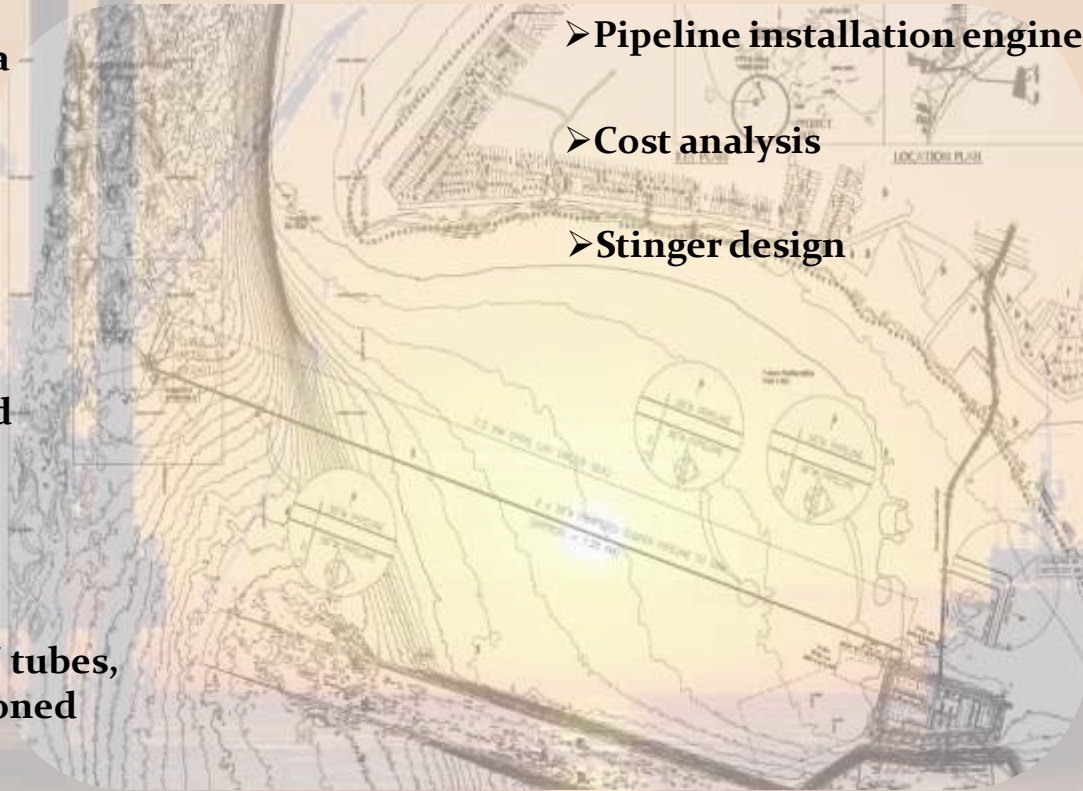

Expertise & Specialization

Mechanical Engineering

- Layout Development
- General Arrangement
- Equipment Sizing and Design
- Specification and selection for cranes, compressors, pumps, air coolers, flare tips
- Fire and Safety
- Maintenance Manuals

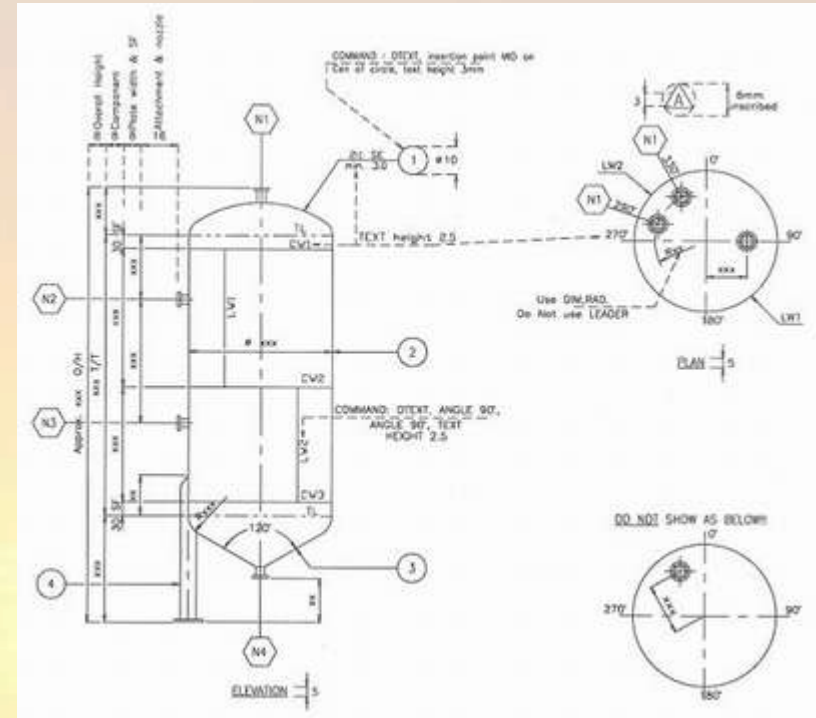

Expertise & Specialization

Process Engineering

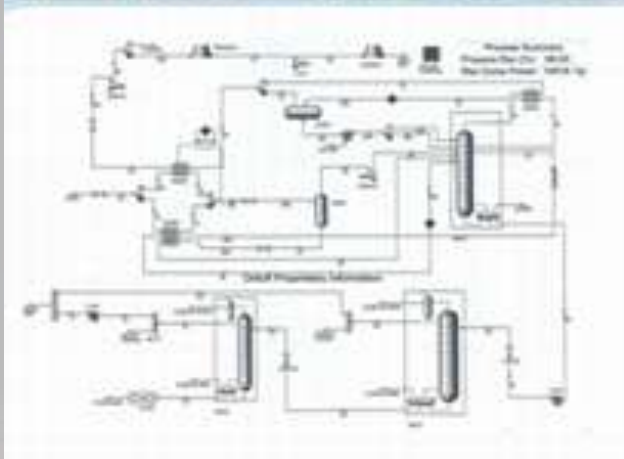

- Process Simulation
- Mass and Heat Balance
- PFDs, MFDs, P&IDs
- Equipment and Line sizing
- Drain/Flare Disposal System
- Flow Control
- Depressuring Analysis
- Operating Manuals
- Multiphase Flow
- Commissioning, Precommissioning
- Corrosion Control
- Cathodic Protection

Expertise & Specialization

Piping Engineering

- Routing
- Size and Material Selection
- 3D Modeling
- Stress Analysis
- Support Design



Expertise & Specialization

Electrical Engineering

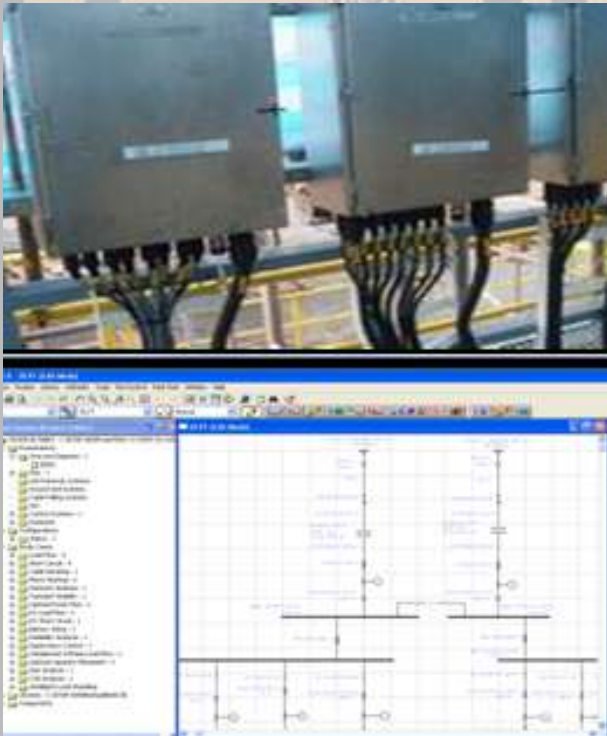

- Load Studies
- Power Design
- Controls : Electric, pneumatics
- Single Line Diagrams
- C&E Hook-up Diagrams
- Wiring Diagrams
- Switch gear
- Generator Hook-up

Expertise & Specialization

Instrumentation Engineering

- Load Studies
- Power Design
- Controls : Electric, pneumatics
- Single Line Diagrams
- C&E Hook-up Diagrams
- Wiring Diagrams
- Switch gear
- Generator Hook-up

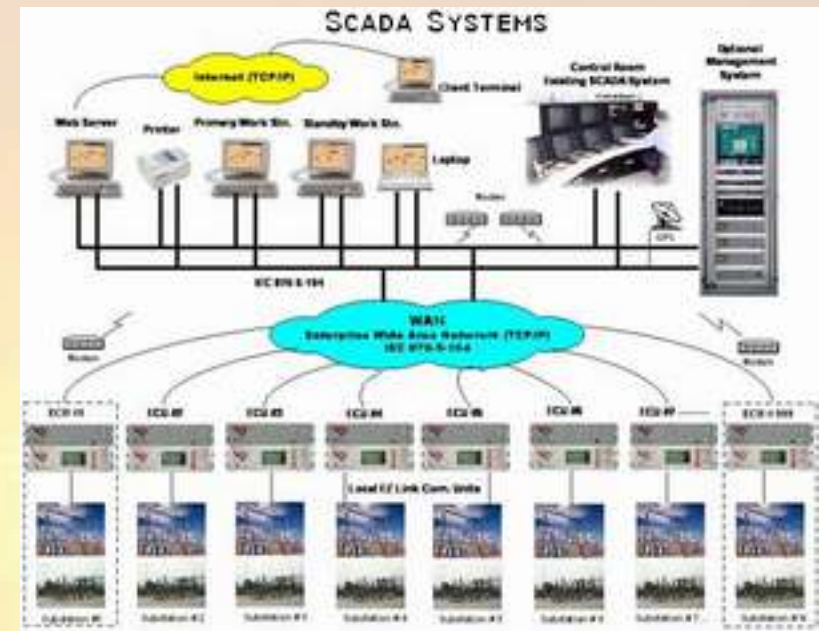

Expertise & Specialization

Project Management Consultancy

- Review EPC bid, assist in Pre-Bid, Technical Bid Evaluation including Commercial proposed by Bidders.
- Project Management, Coordination and Administration of all project activity.
- Review/evaluation and confirmation of Contractor/vendor works and products.
- Project Implementation & Master Schedules.
- Establish construction procedure, site preparation, equipment erection, temporary facilities & interfaces.
- Review of Contractors engineering documents.
- Construction Supervision
- Review/assist Client in testing and commissioning activities.
- Review/assist Client in start-up operation.



Track Records



Client :
Petrochina International Jabung, Ltd

Period : 2014

Location : Jakarta

Project Title :
Detail Engineering of Supply and Installation of BGP Condensate Stripper Overhead Compressor, 3rd Membrane, 3rd Memguard / Molesieve Tower and EMS Packages

ISB Scope of Work :
Multi-discipline engineering and Project Management Services including :

- Detailed Engineering and Studies
- Review Technical Documents

Track Records



Client :
SANTOS SAMPANG PTY LTD

Period : 2011-2013

Location : Jakarta

Project Title :
**BLANKET ENGINEERING SERVICES FOR
VARIOUS PROJECT DEVELOPMENT**

ISB Scope of Work :
**FEED engineering work for Onshore
Receiving Facilities at Grati, Pasuruan, East
Java. Four Finger type slug catcher is
modified at the OPF to allow new liquids
(condensates and water) from the existing
Offshore FPSO and Oyong
Platform.**

Track Records



Client :
PT. PERTAGAS – E1 Corporation
(INDONESIA)

Period : 2008-2009

Location : Jakarta

Project Title :
SOUTH SUMATRA NGL PROJECT

ISB Scope of Work :
FEED engineering work for LPG extraction plant in Sumatra selatan. The scope also included 8” NGL pipeline (89 KM.) from the Extraction Plant, Prabumulih Barat to Pulau Layang. The extent of the pipeline is from the mating outlet flange of the pig launcher at Prabumulih Barat to the inlet mating flange of the pig receiver at Pulau Layang. Another 6” pipeline (3KM) from Pulau layang to Pertamina refinery.

Track Records



Client :
PT. SOUTH SULAWESI LNG

Period : 2014

Location : Jakarta

Project Title :
LNG Plant Production & Export Terminal
Sengkang, South Sulawesi

ISB Scope of Work :

ISB Scope of Work for this project includes detail engineering for :

- Fuel Gas Electric Heater
- Ethane Electric Heater Package
- Butane Electric Heater Package
- Butane Make Up Electric Heater
- Liquid Nitrogen Heater Package
- Nitrogen Generation System
- Warm & Cold Flare
- Ethane and LIN Storage Tank
- Instrument Air & Plant Air System
- Fire Water Pumps
- Firewater Service Water Tank

Track Records



Client :
PT.Surya Eka Perkasa, Tbk

Period : 2014

Location : Jakarta

Project Title :
LPG Extraction Plant

ISB Scope of Work :
ISB Scope of Work for this project includes detail engineering for :

- LPG Storage Tank
- Condensate Storage Tank
- LPG Loading Pump
- Flare Scrubber
- Site Flare
- Site Gas Gen Set
- Site Air Compressor
- Air Compressor Dryer
- Flare Seal Return Pump
- Seal Makeup Pump
- Open Pit Drain Pump
- Fire Water Pump
- Fire Water Jockey Pump

Track Records



Client :
**PT. REKAYASA INDUSTRI / PT.NUSANTARA
REGAS**

Period : 2011

Location : Jakarta

Project Title :
**FLOATING STORAGE REGASIFICATION UNIT
(MUARA KARANG)**

ISB Scope of Work :

The Scope includes :

- **Stability analysis of the pipelay barge**
- **Pipelay analysis during initiation, normay lay, termination, abandon and recovery**
- **Pipelay barge mooring analysis during initiation, normay lay, termination, abandon and recovery**
- **Transportation analysis and stability analysis for material barge**
- **Above water tie in analysis**
- **Riser and spool installation**
- **Shore pull analysis**

Track Records



Client :
PERTAMINA HULU ENERGI
WEST MADURA OFFSHORE

Period : 2011

Location : Jakarta

Project Title :
CUTTING & LIFTING PLAN ENGINEERING
ANALYSIS KE 40 PLATFORM

ISB Scope of Work :

- 1.Review Company Supplied documents**
- 2.Prepare Computer modeling for Topside and Jacket**
- 3.Analysis for temporary support and cradle**
- 4.Evaluate existing load conditions, potential shifts in center of gravity, lift points, rigging requirements, vessel position, etc**
- 5.Lifting Analysis**
- 6.Lifting Aids design and analysis**
- 7.Transportation Analysis**
- 8.Sea fastening and grillage design**

Track Records



Client :
**Oil and Natural Gas Corporation
Ltd.(ONGC) India**

Period : 2007-2009

Location : Jakarta

Project Title :
HEERA REDEVELOPMENT PROJECT

ISB Scope of Work :
**Detail engineering of Heera
Redevelopment project for ONGC - India.
Scope includes :**

- Design of 4 new welhead platform
- Modification to 7 existing platforms,
- 8 nos.rigid submarine pipeline,
- 3 nos. flexi submarine pipelines and subsea cable. This includes installation & hook up, service and pre service conditions of the facilities.

Track Records



Client :
PREMIER OIL

Period : 2011

Location : Jakarta

Project Title :
AGX Deck Extension Installation Review

ISB Scope of Work :
Lifting analysis of West and South AGX Deck Extension. The analysis is to ensure that the West and South AGX Deck Extension structural configuration satisfies to all requirements.

Track Records



Client :
PREMIER OIL

Period : 2011

Location : Jakarta

Project Title :
**Installation & Structural Integrity
Engineering**

ISB Scope of Work :
**-Stress Analysis & Installation of Umbilical
Holding, Bending and laying down**

Track Records



Client :
STAR ENERGY (KAKAP) LTD

Period : 2009-2011

Location : Jakarta

Project Title :
BLANKET ENGINEERING SERVICES

ISB Scope of Work :
Study and Detail Engineering Offshore Platform Facilities, Modification of KF/KG/KRA/KH Platforms

- Platform Subsidence Assessment
- Fuel gas system
- Gas compression system
- Deck extension
- Utility modification etc.

Track Records



Client :
SANTOS SAMPANG PTY LTD

Period : 2006-2008

Location : Jakarta

Project Title :
FPSO SEAGOOD 101 General Engineering Services

ISB Scope of Work :

- **Refurbishment of FPSO Seagood 101**
- **Multidiscipline engineering services for Oyong Field Development.**
- **Construction Supervision/ Engineering Services**

Track Records



Client :
PT. Cakra Bahana - Duta Marine

Period : 2013-2014

Location : Jakarta

Project Title :
Oyong FSO Terminal Rental, Operation and Maintenance Services for (Santos (Sampang) Pty, Ltd.)

ISB Scope of Work :
Design and Engineering Including All Required Analysis, Calculation, Developing Specification, Procedures and Other Engineering Activities in order to execute effectively the FSO conversion, installation and certification

Track Records



Client :
SANTOS

Period : 2014-2016

Location : Jakarta

Project Title :
**Call Out Project Management and
Engineering Services**

ISB Scope of Work :
Project Management Services including :
Implant Personnel
Engineering Supervision

**Engineering Services for new Development
including :**
Feed Engineering
Detail Design Engineering

Track Records



Client :
HESS (Indonesia-Pangkah) Limited

Period : 2013

Location : Jakarta

Project Title :
**Engineering Services for 6" Gas Lift
Pipeline Replacement for HESS
Ujungpangkah**

ISB Scope of Work :
**Pipeline / Riser Detail Design
Load-out, Seafastening and Transportation
Engineering
Pipeline installation and Riser Installation
for the WHP-B and WHP-A.**

Track Records



Client :
PT. PERTAMINA EP – Region KTI

Period : 2012-2014

Location : Jakarta

Project Title :
**Project Management Consultancy (PMC) for
PT. Pertamina EP – Region KTI**

ISB Scope of Work :
**ISB supports PT.PERTAMINA EP Region KTI as
Project Management Consultant to monitor &
supervise developments of production
facilities in Field Bunyu, Sangatta & Sorong.
The scope of work including tanks,
compressors, pumps, separators, piping gas
line, electrical & installation facilities
development.**

Track Records



Client :
PT.PERTAMINA (PERSERO)

Period : 2012-2014

Location : Jakarta

Project Title :
Project Management Consultancy for Arun LNG Receiving-Hub & Re-gasification Terminal Project

ISB Scope of Work :
ISB supports PT.PERTAMINA (PERSERO) as Project Management Consultant for Arun LNG Receiving-Hub & Re-gasification Terminal Project . The scope of the project is primarily to utilize the existing LNG storage and loading facilities as receiving and hub terminals and add the new facilities such as LNG re-gasification and gas delivery to the gas customers.

Track Records



Client :
CONOCO PHILLIPS

Period : 2010

Location : Jakarta

Project Title :
Corridor Mercury Removal
(BEST PROJECT OF THE YEAR
RECOMMENDATION BY BP MIGAS)

ISB Scope of Work :
Detail engineering of Corridor Mercury
Removal in Suban Station (Sumatra)
including :

- 1.Modification existing facilities**
- 2.Additional Equipment for Mercury Removal**
- 3.Tie-In points work**

Contact Us

ISB Engineering Consultants is internationally recognized as a leading Engineering Specialist in the oil and gas market. The company has been involved in numerous large-scale international projects working for oil and gas operators and contractors.

For inquiry, please contact us at :

PT. INDONESIAN SERVICE BUREAU

Prince Center Building Fl.6 Suite 601-605, Jl. Jend. Sudirman Kav 3-4 Jakarta Pusat
10220

Phone +62 21 - 573 3966 Fax +62 21 - 573 8808

Email : info@isb-eng.com

Attn : Mr.Risma Aji / Ms.Mia Hartati





PT. Indonesian Service Bureau

Thank You

Presented by

PT.INDONESIAN SERVICE BUREAU

Headquarter :

Prince Center Building Floor 6 Suite 602-605

Jl. Jenderal Sudirman Kav. 3-4,

Jakarta Pusat, Indonesia

Phone: +6221-573 3966 Fax: +6221-573 8808

Mobile +62 852 1068 5004

Website : www.isb-eng.com

email: info@isb-eng.com

